

HONG KONG EXAMINATIONS AND ASSESSMENT AUTHORITY
HONG KONG DIPLOMA OF SECONDARY EDUCATION EXAMINATION 2016

BIOLOGY PAPER 1

8.30 am – 11.00 am (2 hours 30 minutes)

This paper must be answered in English

GENERAL INSTRUCTIONS

- (1) There are **TWO** sections, A and B, in this Paper. You are advised to finish Section A in about 35 minutes.
- (2) Section A consists of multiple-choice questions in this question paper. Section B contains conventional questions printed separately in Question-Answer Book B.
- (3) Answers to Section A should be marked on the Multiple-choice Answer Sheet while answers to Section B should be written in the spaces provided in Question-Answer Book B. **The Answer Sheet for Section A and the Question-Answer Book B for Section B will be collected separately at the end of the examination.**

INSTRUCTIONS FOR SECTION A (MULTIPLE-CHOICE QUESTIONS)

- (1) Read carefully the instructions on the Answer Sheet. After the announcement of the start of the examination, you should first stick a barcode label and insert the information required in the spaces provided. No extra time will be given for sticking on the barcode label after the 'Time is up' announcement.
- (2) When told to open this book, you should check that all the questions are there. Look for the words '**END OF SECTION A**' after the last question.
- (3) All questions carry equal marks.
- (4) **ANSWER ALL QUESTIONS.** You are advised to use an HB pencil to mark all the answers on the Answer Sheet, so that wrong marks can be completely erased with a clean rubber. You must mark the answers clearly; otherwise you will lose marks if the answers cannot be captured.
- (5) You should mark only **ONE** answer for each question. If you mark more than one answer, you will receive **NO MARKS** for that question.
- (6) No marks will be deducted for wrong answers.

Not to be taken away before the
end of the examination session

There are 36 questions in this section.

The diagrams in this section are NOT necessarily drawn to scale.

Directions: Questions 1 and 2 refer to the schematic diagram below, which shows the structure of a cell membrane:

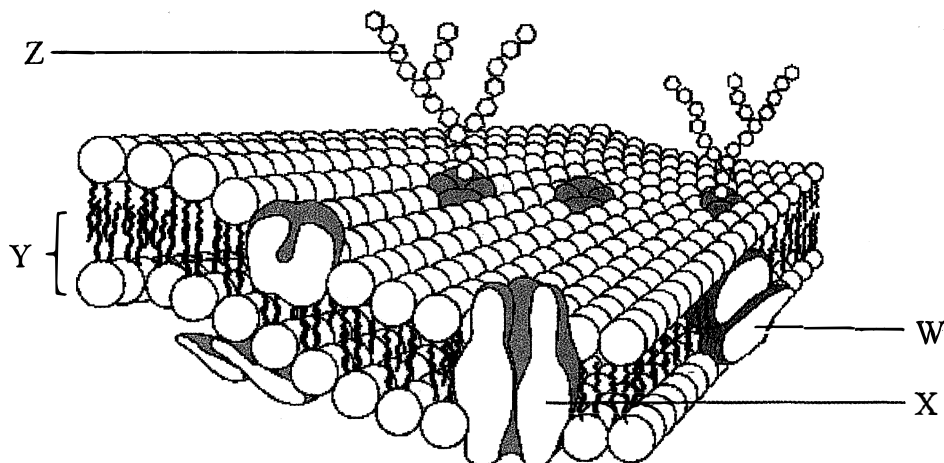

- Which of the following molecules contributes to the fluidity of the cell membrane?
 - W
 - X
 - Y
 - Z
- If the membrane is located at the inner surface of the small intestine, the absorption of amino acids is likely to be achieved via
 - W.
 - X.
 - Y.
 - Z.
- In which of the following pairs of carbohydrates can Benedict's test be used to distinguish the two carbohydrates from one another?
 - sucrose and starch
 - sucrose and maltose
 - glucose and maltose
 - glucose and starch
 - (1) and (3) only
 - (1) and (4) only
 - (2) and (3) only
 - (2) and (4) only
- Which of the following parts of the nucleotide make up the backbone of a polynucleotide strand?
 - sugar and base
 - sugar and phosphate
 - base and phosphate
 - base, sugar and phosphate

Directions: Questions 5 and 6 refer to the diagram below, which shows the nutrition label of a food product:

Nutrition Information	Per serving
Energy	62 Kcal
Protein	3.1 g
Total fat	3.5 g
- Saturated fat	2.4 g
- Trans fat	0 g
Total carbohydrate	4.6 g
- Dietary fibre	0 g
- Sugars	4.6 g
Sodium	44 mg
Calcium	110 mg

5. Which of the following food substances provides most of the energy content in this food product?
- A. fat
 - B. protein
 - C. sodium
 - D. carbohydrate
6. The food product bearing this nutrition label is most likely to be
- A. milk.
 - B. bread.
 - C. sausages.
 - D. potato chips.
7. Which of the following organs produces digestive juice that *does not* contain enzymes?
- A. liver
 - B. mouth
 - C. stomach
 - D. pancreas
8. Which of the following combinations correctly matches the biochemical reaction with the type of metabolism involved?
- | <i>Biochemical reaction</i> | <i>Type of metabolism</i> |
|---|---------------------------|
| A. conversion of glucose to pyruvate | anabolism |
| B. conversion of protein to amino acids | anabolism |
| C. conversion of amino acids to urea | catabolism |
| D. conversion of glucose to glycogen | catabolism |

Directions: Questions 9 and 10 refer to the diagram below, which shows the rate of photosynthesis of a plant under different conditions:

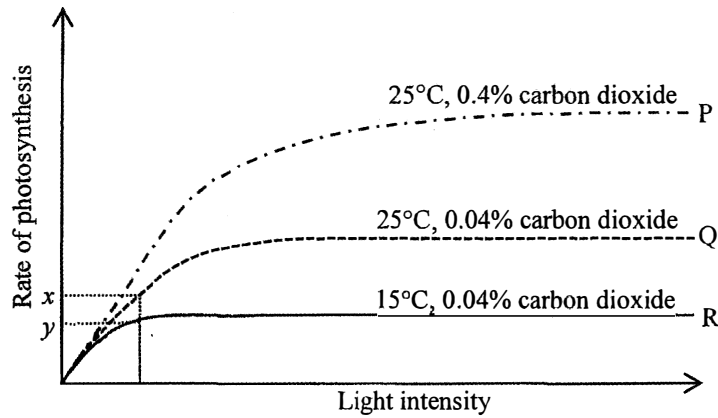

9. The factor(s) that determine(s) the difference in the values of x and y in the diagram is / are
- temperature.
 - light intensity.
 - carbon dioxide concentration.
 - light intensity and temperature.
10. Which of the following descriptions best accounts for the higher rate of photosynthesis of P as compared to Q?
- All conditions are optimum in P.
 - There is a faster diffusion of carbon dioxide into the leaves.
 - More carbon dioxide can be used as raw material for photosynthesis.
 - Carbon dioxide concentration in P is much higher than that in the atmosphere.
11. The graph below shows the changes of the transpiration rate of a plant under different environmental conditions:

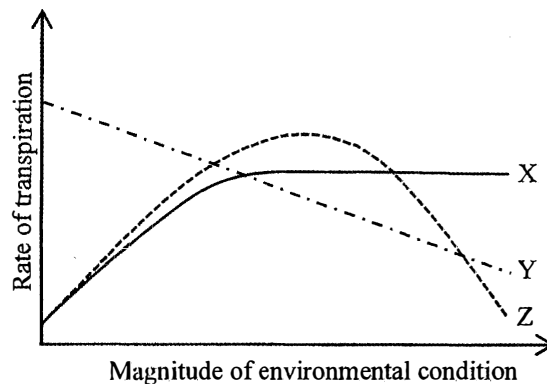

Which of the following correctly matches the environmental conditions represented by X, Y and Z?

- | | X | Y | Z |
|----|-------------------|-------------------|-------------------|
| A. | light intensity | wind speed | relative humidity |
| B. | wind speed | light intensity | relative humidity |
| C. | relative humidity | light intensity | wind speed |
| D. | light intensity | relative humidity | wind speed |

12. A student wants to estimate the stomatal density of the upper and lower epidermis of a leaf using a microscope. Which of the following combinations correctly shows the magnification that should be used and the reason?

- | | <i>Magnification</i> | <i>Reason</i> |
|----|----------------------|-----------------------------|
| A. | low magnification | show a larger field of view |
| B. | low magnification | give a brighter image |
| C. | high magnification | show more cellular details |
| D. | high magnification | give a clearer image |

13. Of the following blood vessels, which one contains blood with the highest urea content?

- A. renal vein
- B. hepatic vein
- C. pulmonary vein
- D. hepatic portal vein

Directions: Questions 14 and 15 refer to the information below. Five new species of eubacteria were discovered in Antarctic ice core samples. The nucleotide sequences of the gene that codes for an essential protein of these new species were compared. The table below shows the number of nucleotide differences between the species:

Species	Number of nucleotide differences				
	P	Q	R	S	T
P	-	4	12	11	22
Q		-	12	11	19
R			-	4	22
S				-	22
T					-

14. Which of the following evolutionary trees best illustrates the phylogenetic relationship of the five species?

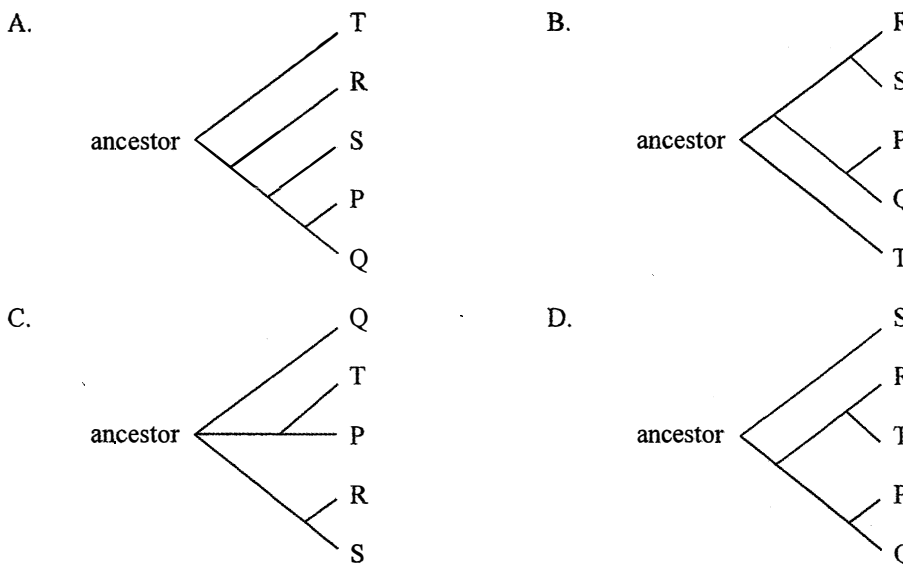

15. Which of the following cell components can be found in these species?

- A. nucleus
- B. cell wall
- C. chloroplast
- D. mitochondrion

Directions: Questions 16 and 17 refer to the diagram below, which shows a section of the heart:

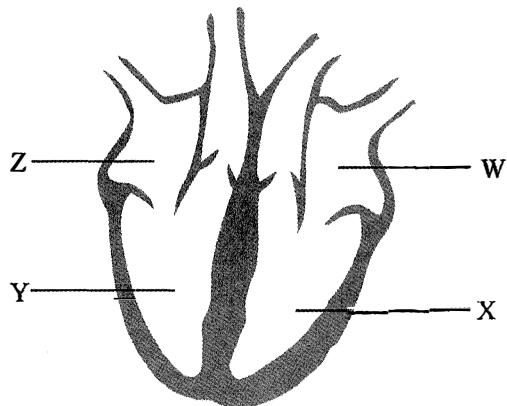

16. When W contracts, which of the following combinations about the conditions of the valves is correct?

- | | <i>Semi-lunar valve</i> | <i>Bicuspid valve</i> |
|----|-------------------------|-----------------------|
| A. | open | open |
| B. | open | closed |
| C. | closed | open |
| D. | closed | closed |

17. Which of the following statements about the heart is correct?

- Z receives oxygenated blood from the lungs.
- Y and Z pump out same volume of blood.
- Blood in Z has higher glucose content than that of W.
- Blood pumped out from Y travels a longer distance than that of X before returning to the heart.

Directions: Questions 18 to 20 refer to the graph below, which shows the change in the DNA content of a cell undergoing a certain division:

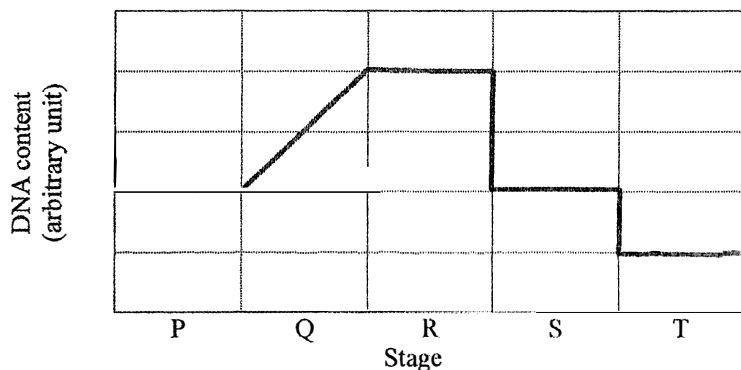

18. Which of the following can be deduced from the graph?

- There are two divisions.
 - There is one DNA duplication.
 - DNA content is halved at the end of the whole process.
- (1) and (2) only
 - (1) and (3) only
 - (2) and (3) only
 - (1), (2) and (3)

19. Which of the following stages best represent(s) interphase?
- P only
 - Q only
 - P and Q only
 - P, Q and R only
20. Sister chromatids separate from one another during the transition from
- P to Q.
 - Q to R.
 - R to S.
 - S to T.

Directions: Questions 21 to 23 refer to the diagram below, which shows the cross section of a young dicotyledonous root:

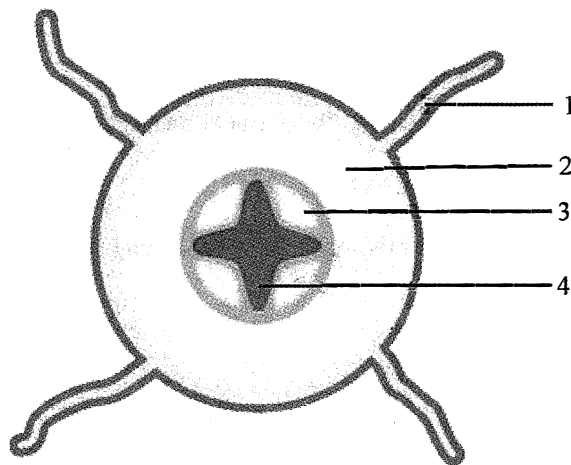

21. Which of the following parts provides rigidity to support the plant?
- 1
 - 2
 - 3
 - 4
22. Which of the following parts is responsible for the transport of food?
- 1
 - 2
 - 3
 - 4
23. Which of the following parts is most likely to have more mitochondria?
- 1
 - 2
 - 3
 - 4

Directions: Questions 24 and 25 refer to the diagram below, which shows an experimental set-up for studying osmosis:

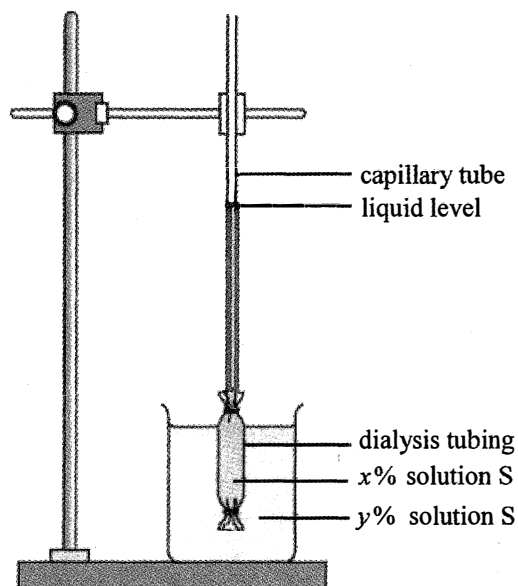

24. After three hours, the liquid level has risen. What can be deduced from this result?
- (1) Solution S diffuses into the dialysis tubing.
 - (2) Value of x is larger than that of y .
 - (3) Solute of solution S cannot pass through the dialysis tubing.
- A. (1) and (2) only
 - B. (1) and (3) only
 - C. (2) and (3) only
 - D. (1), (2) and (3)
25. Which of the following modifications will result in a faster rise in the liquid level?
- A. use a smaller volume of $x\%$ solution S
 - B. use a larger volume of $y\%$ solution S
 - C. use a shorter capillary tube
 - D. use a longer piece of dialysis tubing
26. Which of the following processes in aerobic respiration release NADH?
- (1) glycolysis
 - (2) Krebs cycle
 - (3) oxidative phosphorylation
- A. (1) and (2) only
 - B. (1) and (3) only
 - C. (2) and (3) only
 - D. (1), (2) and (3)
27. Which of the following statements about enzymes is *incorrect*?
- A. Enzymes are produced by cells.
 - B. Enzymes are denatured at extreme temperatures.
 - C. There could be more than one specific enzyme to catalyse the same reaction.
 - D. When an enzyme encounters the same substrates, it always produces the same products.

Directions: Questions 28 and 29 refer to the diagram below, which shows the cells and the associated vessels in a tissue:

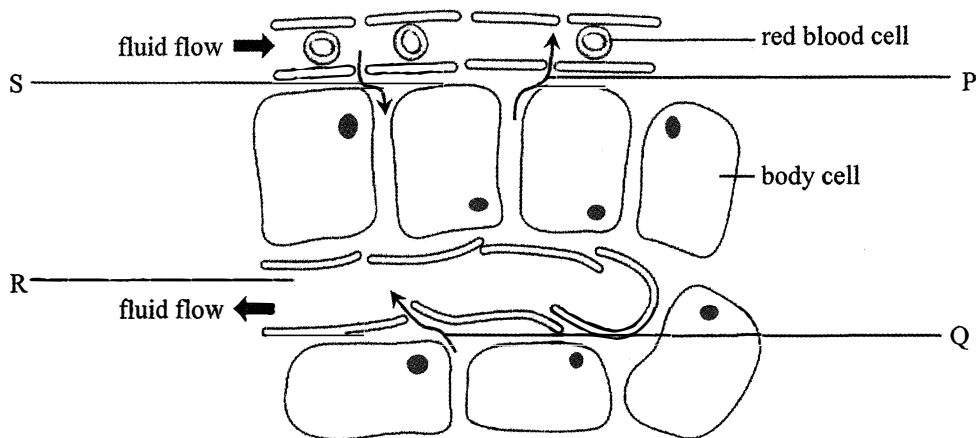

28. Which of the following combinations correctly identifies the major causes of fluid flow represented by P, Q and S?

- | | <i>P</i> | <i>Q</i> | <i>S</i> |
|----|----------------------|----------------------|----------------------|
| A. | osmosis | diffusion | hydrostatic pressure |
| B. | hydrostatic pressure | hydrostatic pressure | diffusion |
| C. | osmosis | hydrostatic pressure | hydrostatic pressure |
| D. | diffusion | diffusion | osmosis |

29. Fluid in R eventually returns to the heart at the

- A. left atrium.
- B. right atrium.
- C. left ventricle.
- D. right ventricle.

30. The following is a food web found in grassland:

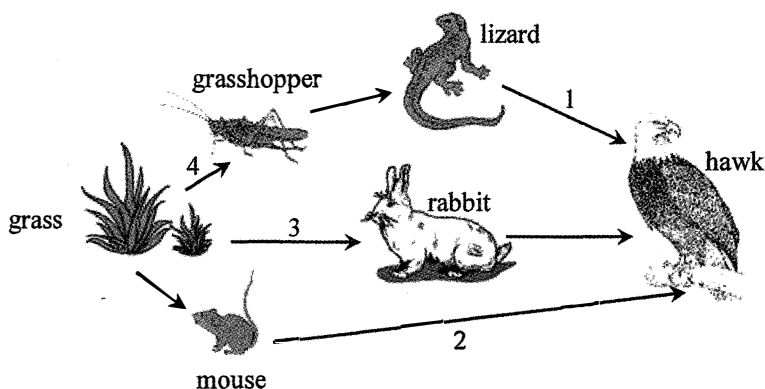

If the energy input for each food chain is the same, the transfer of energy between two trophic levels is the smallest in

- A. 1.
- B. 2.
- C. 3.
- D. 4.

Directions: Questions 31 and 32 refer to the diagram below, which shows the section of a fruit:

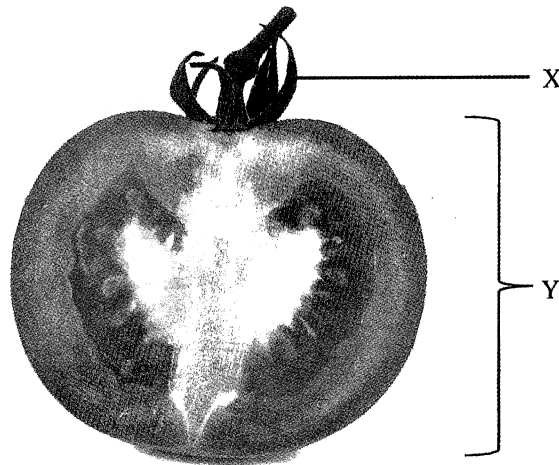

31. Which of the following combinations correctly shows the floral parts that develop into structures X and Y?

	X	Y
A.	carpel	petal
B.	carpel	ovary
C.	sepal	petal
D.	sepal	ovary

32. Structure Y serves as

- (1) food store for seed germination.
- (2) attraction to animals for seed dispersal.
- (3) cushion to protect the seed during falling.

- A. (1) only
- B. (2) only
- C. (1) and (3) only
- D. (2) and (3) only

33. Which of the following organs are protected by the rib cage?

- (1) lung
- (2) liver
- (3) heart

- A. (1) and (2) only
- B. (1) and (3) only
- C. (2) and (3) only
- D. (1), (2) and (3)

34. Symbiotic bacteria found in the root nodules of bean plants are able to convert

- A. nitrite ions to nitrate ions.
- B. nitrogen gas to nitrate ions.
- C. organic nitrogenous compounds to nitrate ions.
- D. nitrogen gas to ammonium ions.

Directions: Questions 35 and 36 refer to the diagram below, which shows an experiment that collects auxins from the tip of coleoptiles under different conditions. After that, the agar blocks are placed on decapitated coleoptiles of the same height:

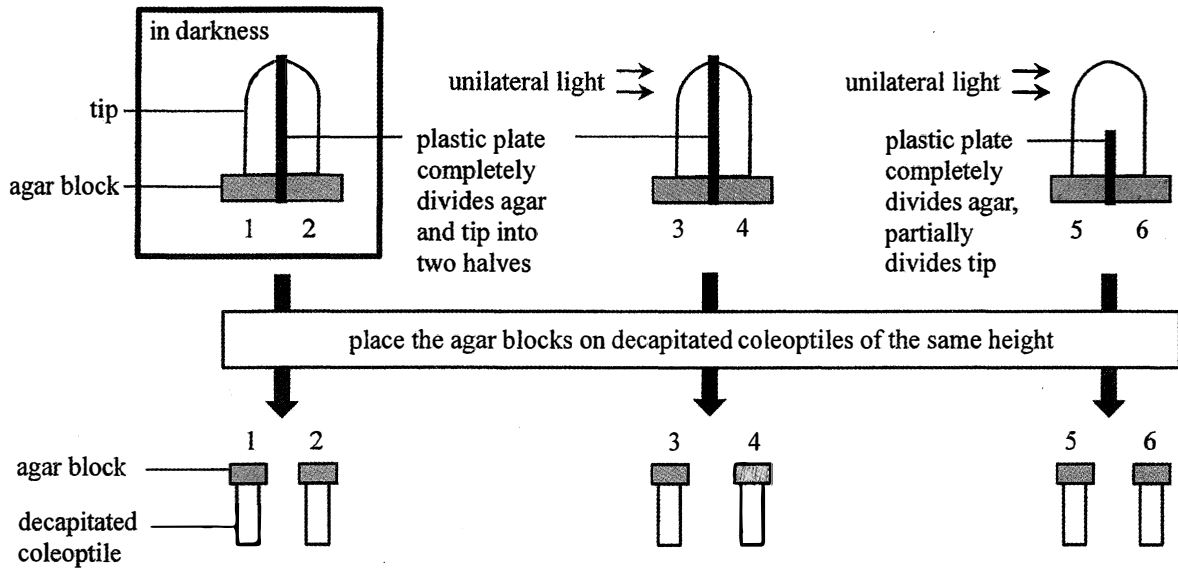

35. Which of the following correctly shows the growth response of the decapitated coleoptiles?

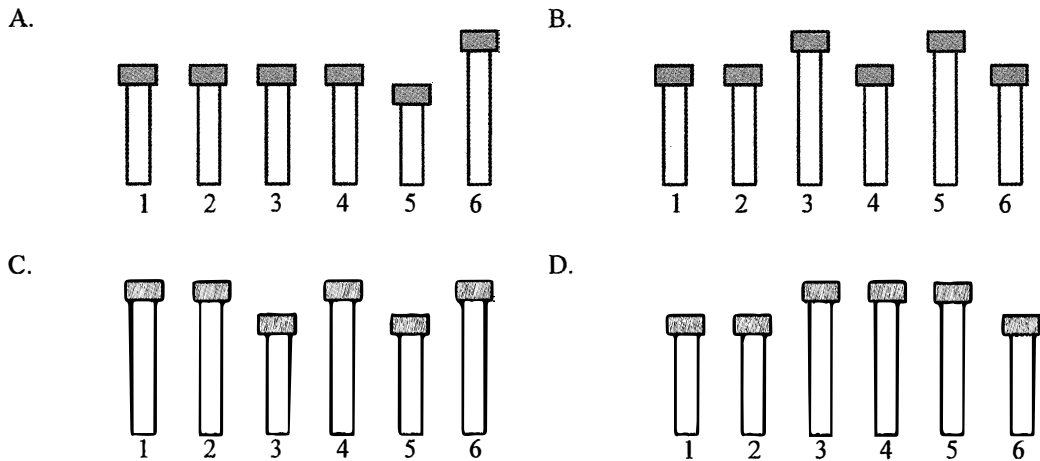

36. Which of the following can be used as a control set-up for the above experiment?

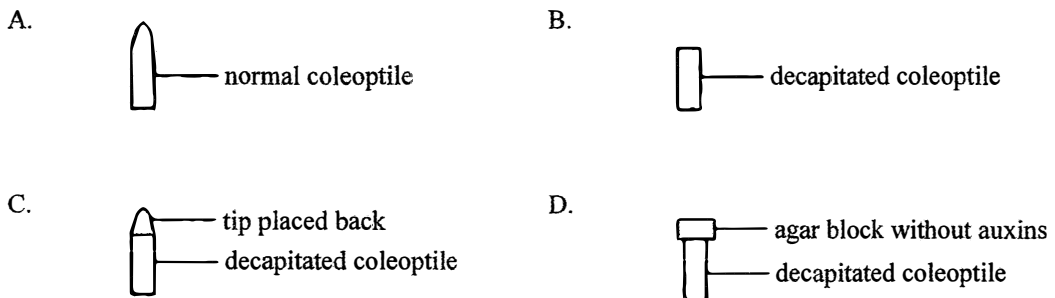

END OF SECTION A

Go on to Question-Answer Book B for questions on Section B

BIOLOGY PAPER 1

SECTION B : Question-Answer Book B

This paper must be answered in English

INSTRUCTIONS FOR SECTION B

- (1) After the announcement of the start of the examination, you should first write your Candidate Number in the space provided on Page 1 and stick barcode labels in the spaces provided on Pages 1, 3, 5, 7 and 9.
- (2) Refer to the general instructions on the cover of the Question Paper for Section A.
- (3) Answer **ALL** questions.
- (4) Write your answers in the spaces provided in this Question-Answer Book. Do not write in the margins. Answers written in the margins will not be marked.
- (5) Supplementary answer sheets will be supplied on request. Write your candidate number, mark the question number box and stick a barcode label on each sheet, and fasten them with string **INSIDE** this Question-Answer Book.
- (6) Present your answers in paragraphs wherever appropriate.
- (7) The diagrams in this section are **NOT** necessarily drawn to scale.
- (8) No extra time will be given to candidates for sticking on the barcode labels or filling in the question number boxes after the 'Time is up' announcement.

Please stick the barcode label here.

Candidate Number



SECTION B

Answer **ALL** questions. Write your answers in the spaces provided.

1. The table below shows the condition which may result from damage to a certain part of the brain. Complete the table by filling in either the condition or the structural part of the brain affected. (3 marks)

<i>Condition</i>	<i>Structural part of the brain</i>
difficulty in breathing	
	cerebellum
difficulty in speech and vision	

2. The following diagram shows a foetus and the associated structures inside the uterus:

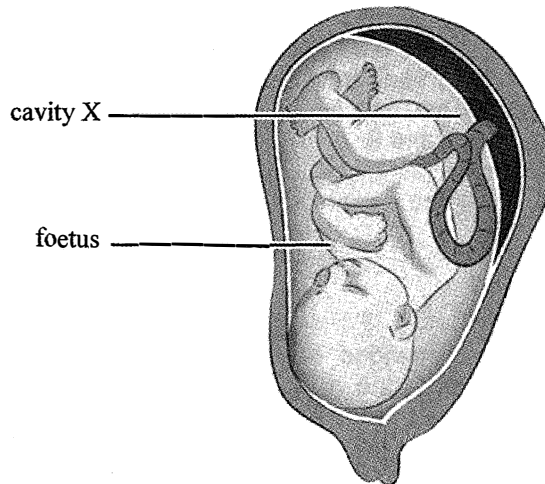

- (a) What is the fluid found in cavity X? (1 mark)

- (b) On the diagram, label the structure where the exchange of materials between the foetal blood and maternal blood takes place. (1 mark)

- (c) Give *two* reasons why foetal blood has to be separated from maternal blood. (2 marks)

Answers written in the margins will not be marked.

Answers written in the margins will not be marked.

Please stick the barcode label here.

3. The diagram below shows the electron micrograph of an organelle:

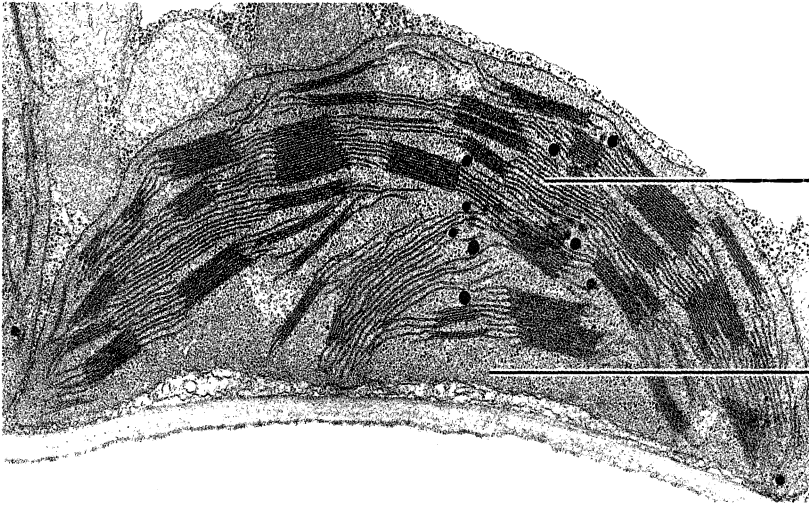

A:

.....

B:

.....

(a) Label A and B. (2 marks)

(b) State a type of plant cell that contains this organelle. (1 mark)

.....
.....

(c) What is the functional relationship between A and B? (3 marks)

.....
.....
.....
.....
.....
.....

Answers written in the margins will not be marked.

Answers written in the margins will not be marked.

Answers written in the margins will not be marked.

4. The following diagrams show the appearance of five flowering plants:



lesser celandine



hyacinth



wild daffodil



primrose

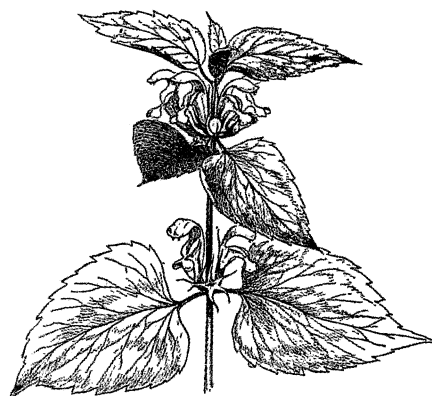

dead nettle

(a) In the following table, put a '✓' in the appropriate boxes to show the features of each flowering plant. (2 marks)

	Leaves with parallel veins	Leaves with network veins	Single flower	Cluster of flowers	Other features
lesser celandine					heart-shaped leaves
hyacinth					funnel-like flowers
wild daffodil					trumpet-like flowers
primrose					club-shaped leaves
dead nettle					two-lipped flowers

Answers written in the margins will not be marked.

Answers written in the margins will not be marked.

Answers written in the margins will not be marked.

Please stick the barcode label here.

(b) Using the information from the table in (a), complete the following dichotomous key: (3 marks)

1a The plant has leaves with parallel veins 2

1b The plant has leaves with network veins 3

2a hyacinth

2b wild daffodil

3a The plant has two-lipped flowers

3b The plant does not have two-lipped flowers

4a lesser celandine

4b primrose

(c) Study the following statement:

The dichotomous key shows that the lesser celandine and primrose have a closer evolutionary relationship.

Do you agree? Explain your answer. (2 marks)

Answers written in the margins will not be marked.

Answers written in the margins will not be marked.

Answers written in the margins will not be marked.

Please stick the barcode label here.

- (c) Explain why quadrats are unsuitable for studying the abundance of crabs on the rocky shore. (2 marks)

6. (a) Kitty and Karen are identical twins. Kitty has preferred meats to vegetables in her diet since her childhood. Kitty suffered from colon cancer at age 35 while Karen had the same disease 10 years later.

- (i) Why did both sisters suffer from colon cancer? (1 mark)

- (ii) Why did the disease occur at different ages? (1 mark)

- (b) Give *two* other lifestyles that increase the risk of suffering from cancer. (2 marks)

Answers written in the margins will not be marked.

Answers written in the margins will not be marked.

Answers written in the margins will not be marked.

7. The diagram below shows a site of injured skin exhibiting an inflammatory response:

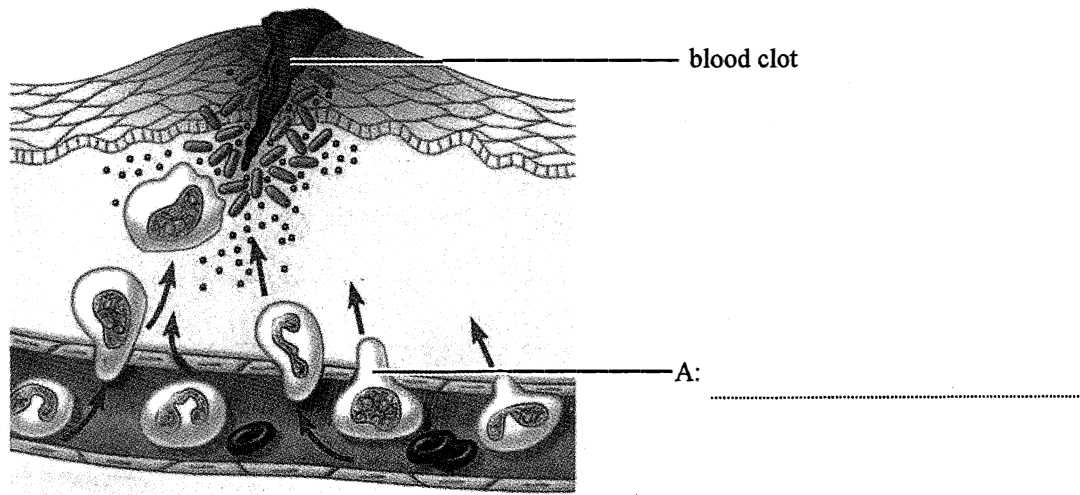

- (a) Label the type of white blood cell represented by cell A in the above diagram. (1 mark)
- (b) Explain why the tissue exhibiting the inflammatory response usually shows symptoms such as redness, swelling and pain. (3 marks)

- (c) Cell A will present the antigens of the invading pathogens to the lymphocytes. Describe what will happen subsequently. (3 marks)

Answers written in the margins will not be marked.

Answers written in the margins will not be marked.

Answers written in the margins will not be marked.

Please stick the barcode label here.

8. In 1930s, a Danish biologist J. Hämmerling tried to find out where the genetic information was stored inside the eukaryotic cell. He used some unicellular algae called *Acetabularia* to carry out a series of experiments. The diagram below shows the morphology of two species of algae used in his study:

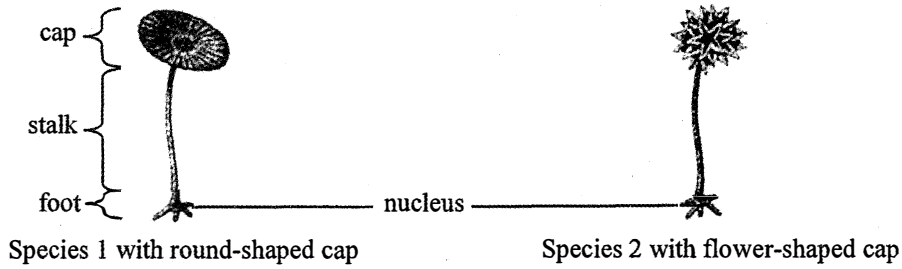

He divided Species 1 into two groups, removing the cap from one group (I) and the foot from another group (II). He then observed if any regeneration occurred in the remaining parts. The diagram below shows the treatments and the results:

	<i>Treatment</i>	<i>Result</i>
I	<p>cut</p> <p>Removing the cap from Species 1</p>	
II	<p>cut</p> <p>Removing the foot from Species 1</p>	

- (a) Describe the results of the above experiment. (2 marks)

Answers written in the margins will not be marked.

Answers written in the margins will not be marked.

Answers written in the margins will not be marked.

(b) Based on the results, Hämmerling hypothesized that:

The hereditary information is stored in the foot of the algal cell.

Hämmerling further studied the expression of hereditary information by grafting the stalk of Species 1 to the foot of Species 2. After grafting, the cap formed from the first regeneration showed a mixed morphology (III). He then removed the regenerated cap. The cap formed from the second regeneration looked exactly the same as Species 2 (IV). The diagram below shows the treatments and the results:

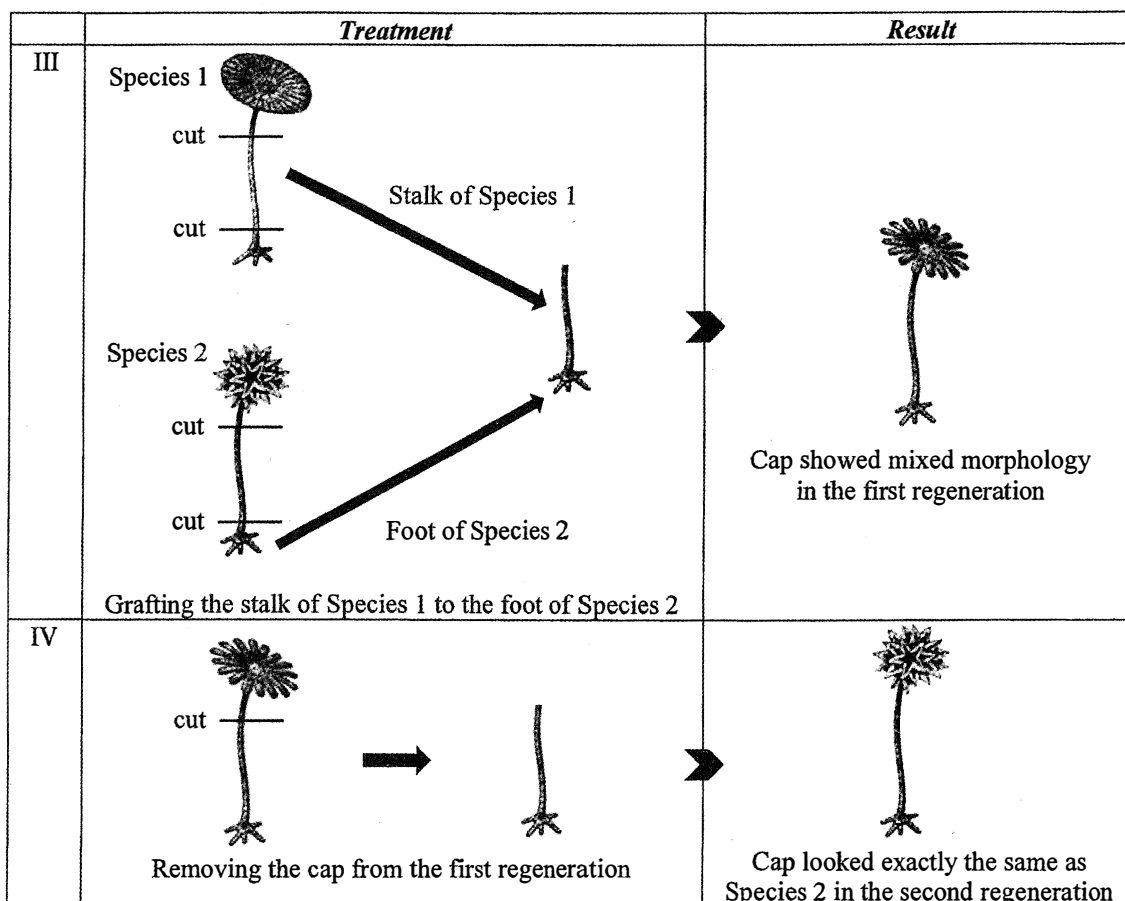

(i) Hämmerling concluded that when the cut stalk was transplanted, it contained some short-lived instruction derived from the foot of Species 1, resulting in a mixed morphology of the cap in the first regeneration.

(1) Suggest the type of biomolecule that carried the short-lived instruction. (1 mark)

(2) How could the biomolecule suggested in (1) affect the morphology of the cap? (2 marks)

Answers written in the margins will not be marked.

Answers written in the margins will not be marked.

Answers written in the margins will not be marked.

9. To study the effect of mineral deficiency on shoot and root dry masses, bean plants were grown in a complete nutrient solution (a solution containing all essential nutrients for growth) or a nutrient solution without either phosphorus (P) or magnesium (Mg) for 12 days respectively. The dry masses of shoot and root were then measured. The results are shown in the graphs below:

Key: — complete nutrient solution
 - - - - P deficiency
 - - - - Mg deficiency

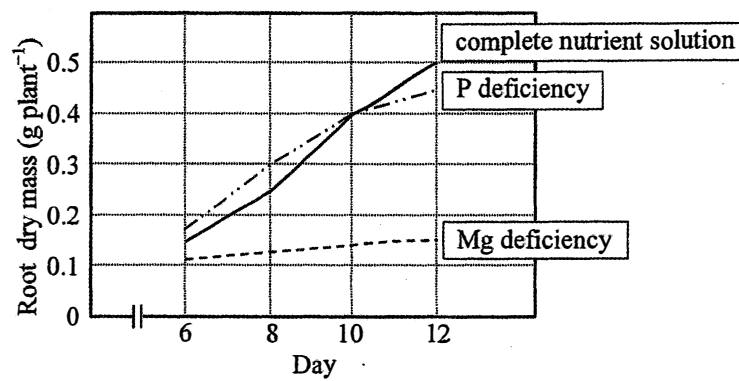
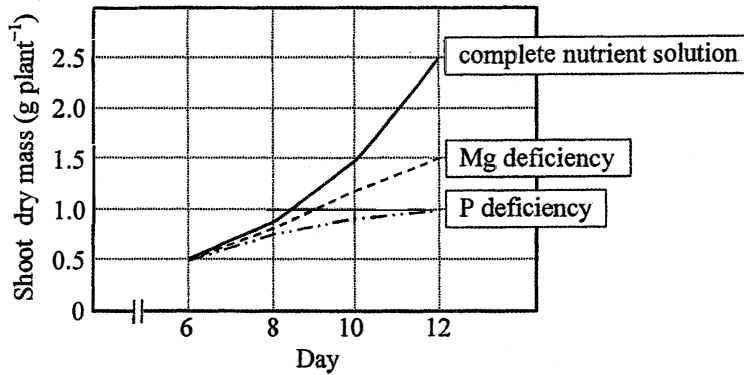

- (a) Briefly describe how the dry mass of a plant can be determined. (2 marks)

Answers written in the margins will not be marked.

Answers written in the margins will not be marked.

Answers written in the margins will not be marked.

(b) The leaves of the bean plants grown under Mg deficient conditions appeared yellow.

(i) Why did the leaves appear yellow? (1 mark)

(ii) Use this phenomenon to explain the results of the shoot dry mass and root dry mass of the bean plants under Mg deficient conditions. (3 marks)

(c) (i) Explain the difference in the overall dry mass of the plant grown under P deficient conditions and that in the complete nutrient solution. (2 marks)

(ii) It was hypothesized that P inhibits the export of photosynthetic products from leaves to roots. Use this hypothesis to explain the results of the shoot dry mass and root dry mass of the bean plants under P deficient conditions. (3 marks)

Answers written in the margins will not be marked.

Answers written in the margins will not be marked.

Answers written in the margins will not be marked.

10. Colour blindness is an X-linked recessive genetic disorder. The pedigree below shows the inheritance of colour blindness in a family:

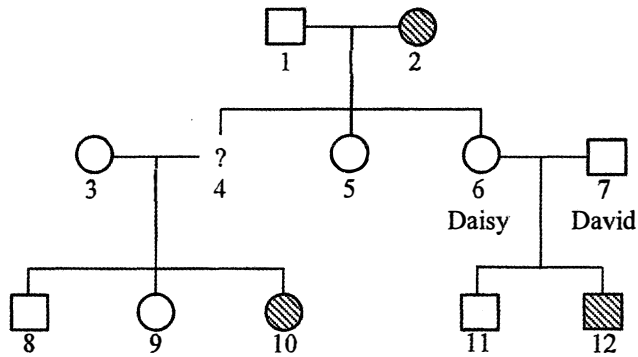

Key:

- female with normal colour vision
- male with normal colour vision
- female with colour blindness
- male with colour blindness

- (a) Colour blindness is due to the abnormal development of photoreceptors. State the relevant type of photoreceptors and the location inside the eyeball where these photoreceptors are most abundant. (2 marks)

- (b) Given that the dominant allele of colour vision is represented by R while the recessive allele is represented by r, determine all the possible genotypes and phenotypes of the offspring of individuals 1 and 2 using a genetic diagram. (5 marks)
(Note: Punnett square is not accepted)

Answers written in the margins will not be marked.

Answers written in the margins will not be marked.

Answers written in the margins will not be marked.

(c) Draw all possible representation(s) for individual 4 with reference to the key of the pedigree. (1 mark)

(d) Daisy (individual 6) has recently given birth to a baby girl. Since one of her sons suffered from colour blindness (individual 12), Daisy worried that their daughter would have colour blindness too. David (individual 7) reassured her by saying that:

Don't worry. Our daughter will be fine because I have normal colour vision!

Justify David's claim. (5 marks)
(Note: Marks will not be awarded for genetic diagrams.)

Answers written in the margins will not be marked.

Answers written in the margins will not be marked.

Answers written in the margins will not be marked.

Answers written in the margins will not be marked.

A large rectangular area with horizontal ruling lines for writing answers. The lines are evenly spaced and cover most of the page's width and height.

Answers written in the margins will not be marked.

Answers written in the margins will not be marked.

Answers written in the margins will not be marked.

Answers written in the margins will not be marked.

END OF PAPER

Sources of materials used in this paper will be acknowledged in the *Examination Report and Question Papers* published by the Hong Kong Examinations and Assessment Authority at a later stage.

Answers written in the margins will not be marked.