

HONG KONG CHINESE WOMEN'S CLUB COLLEGE

Annual Examination (2021-2022)

Secondary 6 Physics

Paper 1 - Section A

Question Paper

21/01/2022 8:30 a.m. – 11:00 a.m.

Time allowed: 2.5 hour

Full mark: 135

Instructions:

1. This paper consists of TWO sections, Section A and B. Section A carries 51 marks and Section B carries 84 marks.
2. Section A: Write your answers in the spaces provided on MC Answer Sheet
Section B: Write your answers in the spaces provided in the Question-Answer Book.

Stationery: 1 Question Paper, 17 pages (excluding white front cover)
 1 MC Answer Sheet
 1 Question-Answer Book, 18 pages (excluding coloured front cover)
 1 Rough Work Sheet

Classes	No. of Pupils	Examination Centre
6S1	23	Hall
6S2	22	Hall
6X1	2	Rm 106
6X2	1	Rm 106
Total:	48	

Section A : Multiple-Choice Questions (51 marks, 1.5 marks each)

Answer **ALL** questions on the boxes provided on the MC answer sheet.

1. A wax block of specific heat capacity $2000 \text{ J kg}^{-1} \text{ K}^{-1}$ is heated by a heater of constant power. The variation of temperature with time is given below.

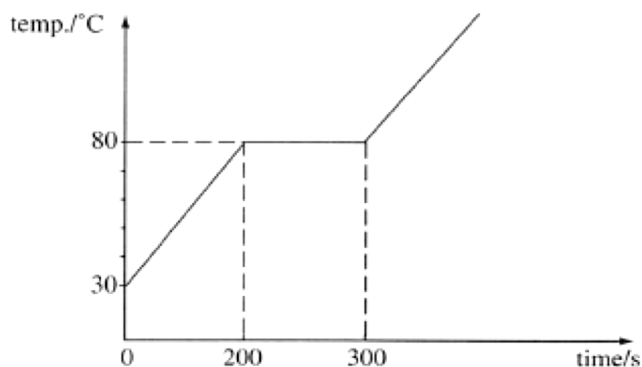

Assuming no heat is lost to the surroundings. What is the specific latent heat of fusion of the wax?

- A. $3 \times 10^4 \text{ J kg}^{-1}$
B. $5 \times 10^4 \text{ J kg}^{-1}$
C. $8 \times 10^4 \text{ J kg}^{-1}$
D. $15 \times 10^4 \text{ J kg}^{-1}$
2. As shown in the figure below, a man is on the bed of nails. Which of the following statements are incorrect?



- (1) If more nails are put on the bed, the man feels more pain.
(2) If the man stands on the nail bed instead, he would be more easily injured.
(3) A heavier man must experience greater pressure from the bed than a lighter man.
- A. (1) and (2) only
B. (1) and (3) only
C. (2) and (3) only
D. (1), (2) and (3)

3. The diagram below shows the apparatus to investigate the relation between pressure and volume of a gas at constant temperature.

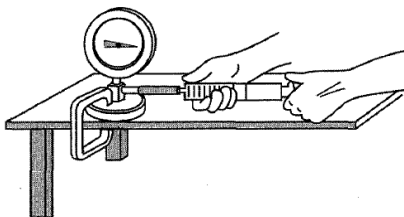

The graph below shows the results of the investigation at room temperature of 27 °C.

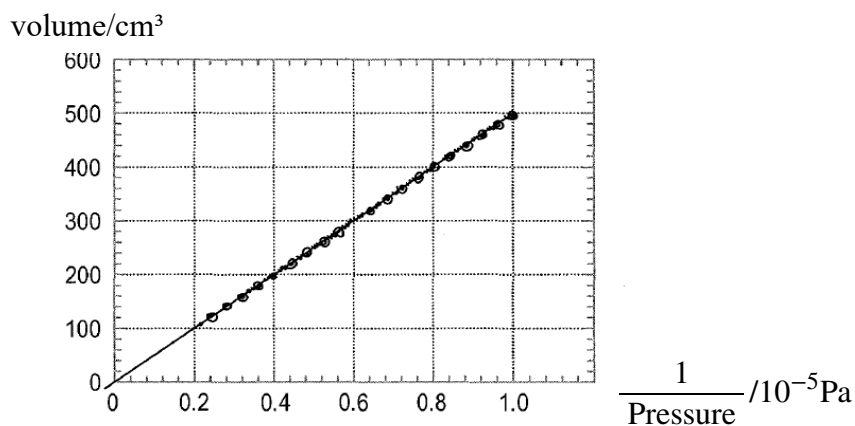

Find the number of moles of air employed in the above experiment.

- A. 0.01
 B. 0.02
 C. 0.03
 D. 0.05
4. A tennis ball is released from rest above the floor and bounces several times on the floor. The following graph shows the variation of velocity of the ball with time. The upward direction is taken to be positive. Which of the following statements are correct?

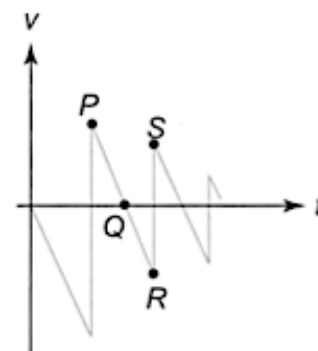

- (1) At point *P*, the ball reaches the highest point.
 (2) At point *Q*, the ball is instantaneous at rest.
 (3) From point *R* to point *S*, the ball bounces on the floor.
- A. (1) and (2) only
 B. (1) and (3) only
 C. (2) and (3) only
 D. (1), (2) and (3)

5. A windlass is used to raise water from a well as shown below. By turning the axle, a bucket of total mass 25 kg is raised up by a rope with increasing speed.

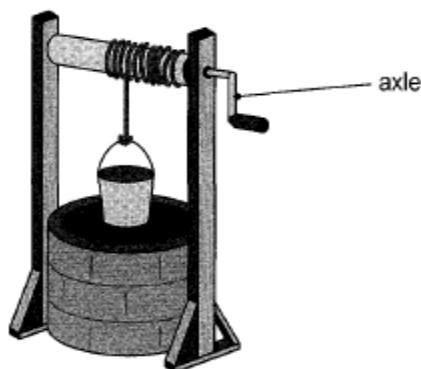

If the maximum tension that the rope can stand is 350 N, what is the maximum acceleration of the bucket without breaking the rope?

- A. 2.0 m s^{-2}
B. 3.1 m s^{-2}
C. 4.2 m s^{-2}
D. 5.3 m s^{-2}
6. An object of mass 1.6 kg is attached to the end of a light string which is then hung over a light frictionless pulley fixed to the wall. An object of mass 0.9 kg is then attached to the other end of the string as shown below.

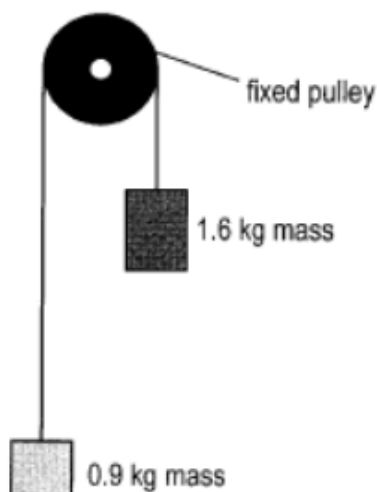

When the system is released, what is the tension in the light string?

- A. 2.7 N
B. 8.8 N
C. 11.3 N
D. 12.5 N

7. Which of the following vector diagrams represent(s) forces in equilibrium?

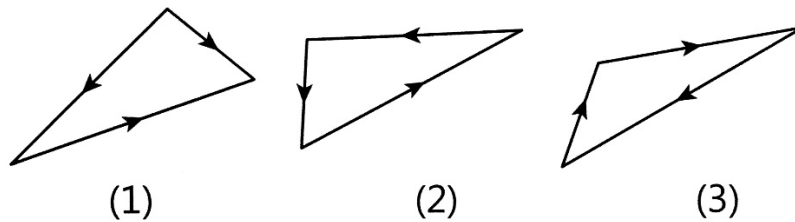

- A. (1) only
- B. (1) and (2) only
- C. (2) and (3) only
- D. (1), (2) and (3)

8. The front and rear wheels of a stationary car are 1.8 m apart. If the reaction force on the front wheel is 1.2 times that on the rear wheels. Find the distance of the centre of gravity of the car from the front wheel.

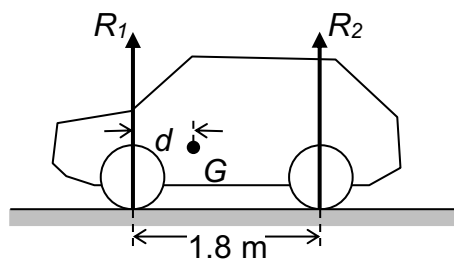

- A. 0.782 m
- B. 0.818 m
- C. 0.900 m
- D. 0.982 m

9. A bowling ball is travelling at a speed of 5 m s^{-1} towards a pin as shown.

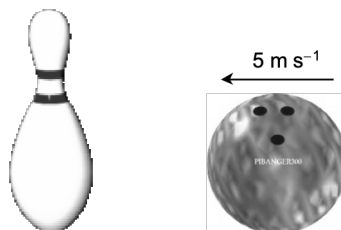

After collision, the speed of the ball reduces to 4 m s^{-1} . Suppose the ball has six times the mass of the pin. Find the speed of the pin just after it bounces off from the ball.

- A. 4 m s^{-1}
- B. 5 m s^{-1}
- C. 6 m s^{-1}
- D. 7 m s^{-1}

10. The figure below shows the motion of balls X and Y before and after a collision. Both balls move on a smooth horizontal ground. Y is at rest before the collision.

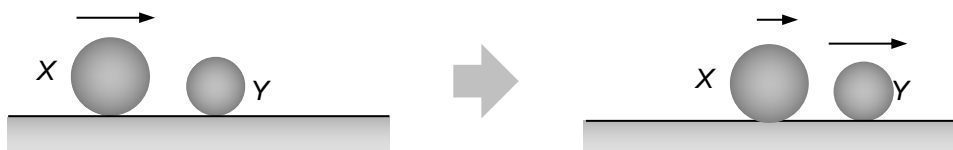

Which of the following statements about the collision must be correct?

- (1) The total momentum of the balls is conserved.
 - (2) The total KE of the balls is conserved.
 - (3) The magnitude of the force of impact acting on Y by X is equal to that on X by Y .
- A. (1) only
 B. (3) only
 C. (1) and (3) only
 D. (2) and (3) only
- 11.

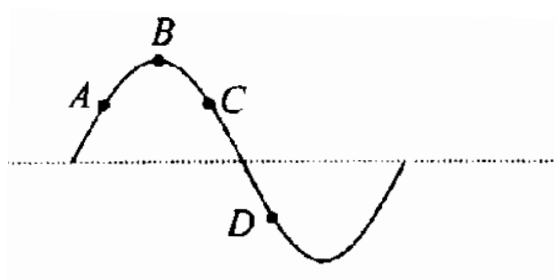

The above figure shows a transverse wave propagating along a string. At the instant shown, the particle D on the string is moving downward. Which of the following deductions is/are correct?

- (1) The wave is propagating to the left.
 - (2) Particle B takes longer than particle A to return for the first time to the respective equilibrium positions along the dotted line.
 - (3) Particles C and D are moving in opposite directions at the instant shown.
- A. (1) only
 B. (3) only
 C. (1) and (2) only
 D. (2) and (3) only

12. A longitudinal wave is travelling from left to right in a medium. The figure below shows the positions of the particles in the medium what a wave passes by at a certain instant and their equilibrium positions.

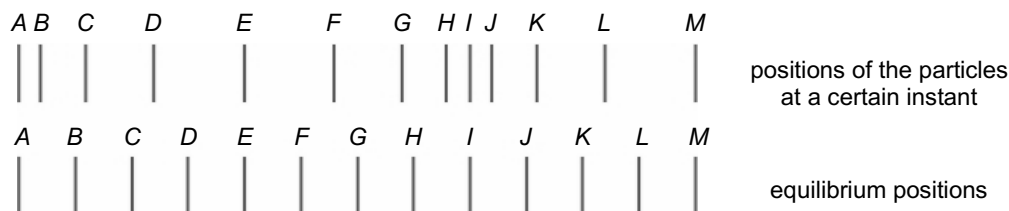

Which of the following statement is/are **incorrect**?

- (1) The distance between particles *E* and *M* is equal to one wavelength.
 - (2) Particles *A* and *I* are momentarily at rest.
 - (3) Particles *A* and *I* are moving to the left.
- A. (1) only
 B. (2) only
 C. (1) and (2) only
 D. (2) and (3) only
13. In a Young's double slit experiment, a beam of light of wavelength $0.4 \mu\text{m}$ passes through a double slit and falls onto a screen.

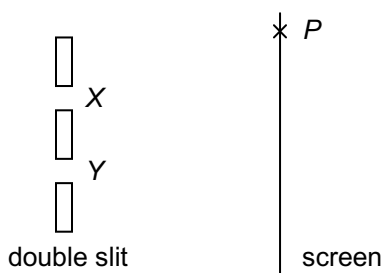

If the path difference at point *P* on the screen is $3 \mu\text{m}$, which of the following are correct?

- (1) The 8th order dark fringe forms at *P*.
 - (2) The fringe separation on the screen increases if a red light source is used.
 - (3) *P* becomes a bright fringe if light of wavelength 500 nm is used.
- A. (1) and (2) only
 B. (1) and (3) only
 C. (2) and (3) only
 D. (1), (2) and (3)

14. In a Young's double slit experiment, monochromatic light shines on a pair of narrow slits and evenly spaced bright fringes are observed on a screen. The experiment is repeated using lights of different wavelengths. The following table shows the data recorded:

Trial	Wavelength of light/nm	Slit separation/mm	Fringe separation/mm	Distance from the slits to the screen/m
1	500	0.2	2.0	Y
2	600	0.2	X	$0.5Y$

Find X and Y .

- | | X/mm | Y/m |
|----|---------------|--------------|
| A. | 1.2 | 0.8 |
| B. | 1.2 | 1.0 |
| C. | 2.4 | 0.8 |
| D. | 2.4 | 1.0 |

- 15.

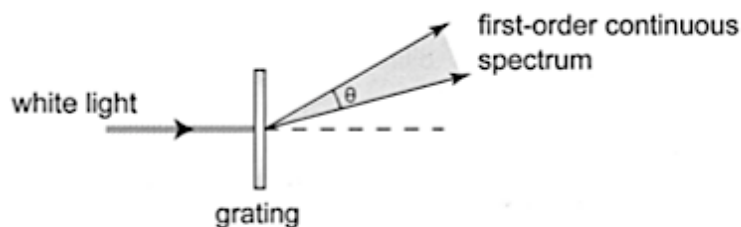

The diagram shows the first-order continuous spectrum formed when a parallel beam of white light is incident normally on a diffraction grating. (The higher order continuous spectra are not shown). The grating has 500 lines per mm. What is the angular spread θ of this spectrum?

(White light covers the range of wavelengths from 400 nm to 700 nm.)

- A. 8.6°
- B. 9.0°
- C. 11.5°
- D. 20.5°

16.

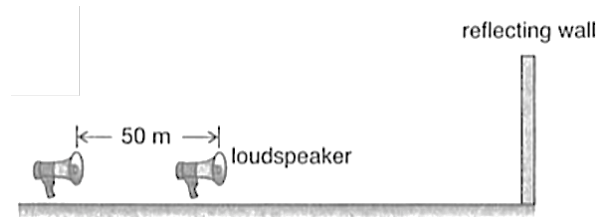

A loudspeaker sends a sound pulse towards a reflecting wall and the echo of the pulse is received 5 s later. Then the loudspeaker moves backwards by 50 m and sounds a pulse again. This time the echo of the pulse is received 5.3 s later. Find the speed of sound.

- A. 83 m s^{-1}
- B. 167 m s^{-1}
- C. 300 m s^{-1}
- D. 333 m s^{-1}

17. Which of the following is not an application of ultrasound?

- A. Detecting the depth of the sea and shoals of fish
- B. Detecting cracks in railway tracks
- C. Remote controlling electrical appliances
- D. Spectacles for the blind people which work on the same principle as bats used for navigation

18.

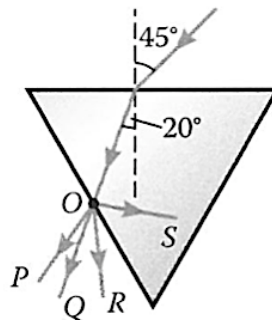

A light ray strikes on an equilateral triangular prism as shown. Which of the following best shows the light ray leaving O ?

- A. P
- B. Q
- C. R
- D. S

19. Which of the following ray diagrams may correctly show the relationship between the object O , image I and the focus F of the lens?

A.

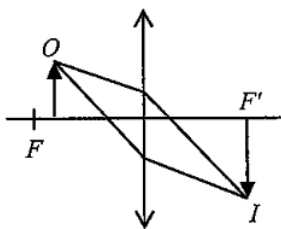

B.

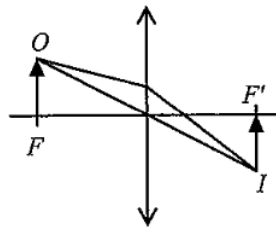

C.

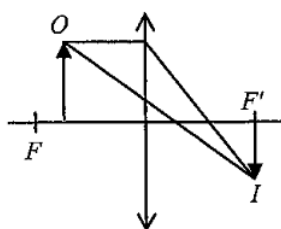

D.

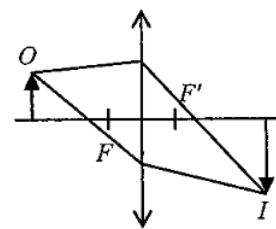

20. On a sunny day, Dave puts a lens of focal length f above some dead leaves as shown and the leaves burn after a while.



Which type of lens does he use? What is the possible distance between the leaves and the lens?

	Lens	Distance
A.	convex	f
B.	convex	$2f$
C.	concave	f
D.	concave	$2f$

21. Points A, B, C and D are on a straight line as shown such that $AB=BC=CD$. Two point charges $+2q$ and $-q$ are fixed at A and C respectively. Another point charge Q is fixed at D .



If the electric field at B is zero, find Q .

- A. $-4q$
 - B. $-q$
 - C. $+3q$
 - D. $+12q$
22. A particle of mass 2 g carries a charge of $-3 \times 10^{-7}\text{ C}$. When it is put between two parallel charged plates separated by 1 cm , it moves downwards with an acceleration of 10 m s^{-2} . What is the voltage across the metal plates and what is the direction of the electric field between the plates? Neglect the effect of gravity.

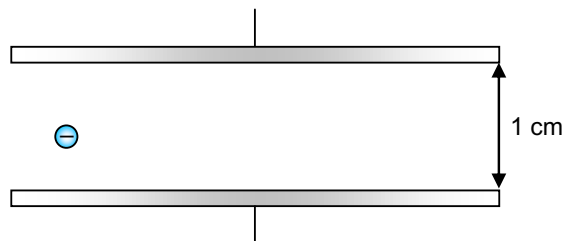

- | | Voltage | Direction of electric field |
|----|----------------|------------------------------------|
| A. | 654 V | upwards |
| B. | 654 V | downwards |
| C. | 667 V | upwards |
| D. | 667 V | downwards |

23. Which of the following networks has the smallest equivalent resistance?

A.

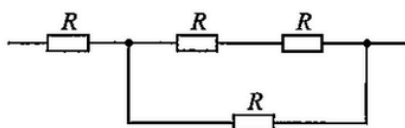

B.

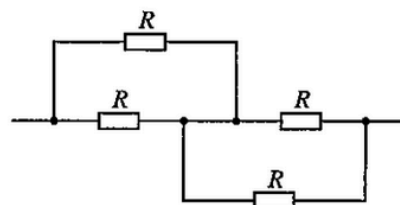

C.

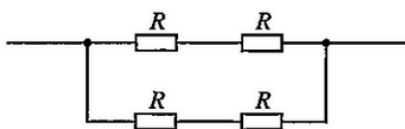

D.

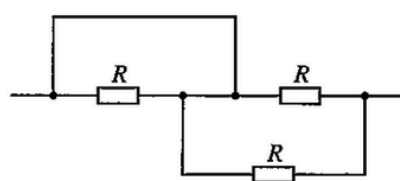

24. In the circuit below, the battery has an e.m.f. of 12 V. The ammeter reads 0.4 A.

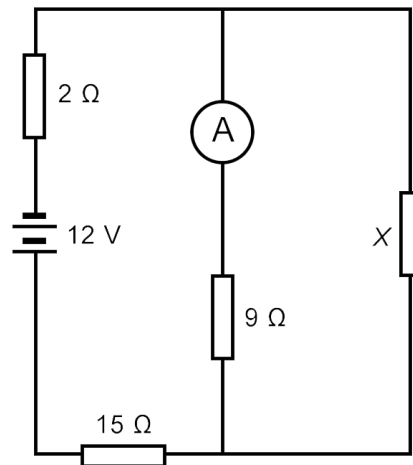

What is the resistance of X ?

- A. 38Ω
- B. 45Ω
- C. 51Ω
- D. 60Ω

25.

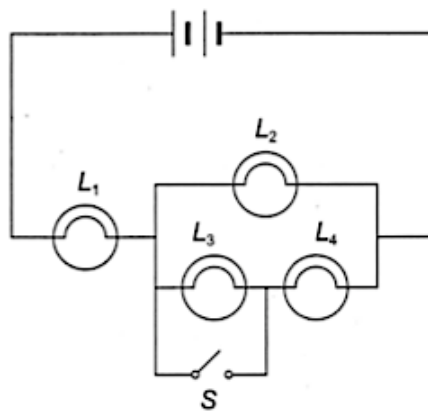

In the circuit shown, the four lamps L_1 , L_2 , L_3 and L_4 are identical. If switch S is closed, which of the following statements are correct?

- (1) The brightness of lamp L_1 increases.
- (2) The brightness of lamp L_2 decreases.
- (3) The brightness of lamp L_4 decreases.

- A. (1) and (2) only
- B. (1) and (3) only
- C. (2) and (3) only
- D. (1), (2) and (3)

26. Three long parallel straight wires X , Y and Z are placed side by side as shown. The currents in X and Y flow into the paper while the current in Z flows out of the paper. The currents in X and Z are equal in size.

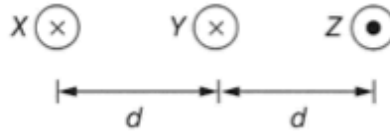

The net force per unit length acting on X is zero. Which of the following statements is/are correct?

- (1) The net force per unit length on Y is zero.
 - (2) The size of the current in Z is twice that in Y .
 - (3) The force per unit length on Z by X is equal to that on Z by Y .
- A. (2) only
 B. (1) and (3) only
 C. (2) and (3) only
 D. (1), (2) and (3)
27. A charged particle enters a uniform magnetic field of field strength B with a speed v making an angle 90° with the boundary of the field. The magnetic field points out of the paper and the particle leaves the field at the same boundary as shown. Which of the following statements is/are correct?

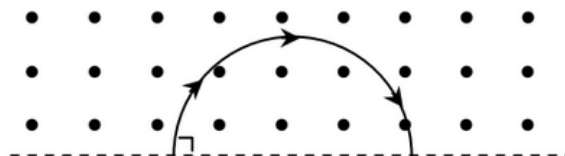

- (1) The particle carries negative charge.
 - (2) The time of transit for the particle in the magnetic field is independent of the speed v .
 - (3) The radius of the semicircle travelled by the particle in the magnetic field is inversely proportional to the field strength B .
- A. (1) and (2) only
 B. (1) and (3) only
 C. (2) and (3) only
 D. (1), (2) and (3)

28. A metal rod PO is rotated about the hinge O at a uniform rate in a uniform B -field. An e.m.f. is induced across PO . Which of the following statements are correct?

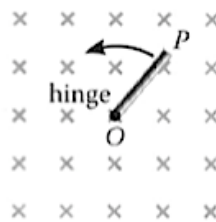

- (1) The induced e.m.f. across PO is constant.
 (2) P is at a higher potential than O .
 (3) The faster the rod rotates, the greater the induced e.m.f.
- A. (1) and (2) only
 B. (1) and (3) only
 C. (2) and (3) only
 D. (1), (2) and (3)
29. Coil XY is connected to a load. When bar magnet PQ moves away from the coil, a current I is induced in the direction as shown.

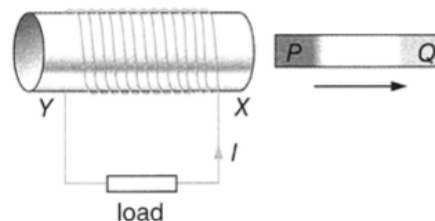

- Which of the following statements is/are correct?
- (1) End X of the coil is an N-pole.
 (2) End P of the magnet is an N-pole.
 (3) The coil exerts a force pointing towards the left on the magnet.
- A. (1) only
 B. (1) and (3) only
 C. (2) and (3) only
 D. (1), (2) and (3)
30. A '220 V, 100 W' lamp is connected to a sinusoidal voltage source and is working at its rated value. What is the peak current flowing through the lamp?
- A. 3.11 A
 B. 2.2 A
 C. 0.64 A
 D. 0.45 A

31. A transformer of turns ratio $N_s : N_p = 1 : 40$ is used to step down a 220 V a.c. voltage. Four identical bulbs, each of resistance 10Ω , are connected in parallel to the secondary coil.

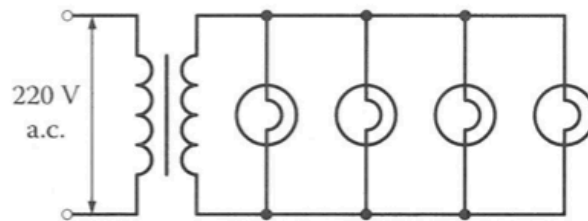

If the efficiency of the transformer is 90%, find the current in the primary coil.

- A. 13.8 mA
 B. 15.3 mA
 C. 55.0 mA
 D. 61.1 mA

32.

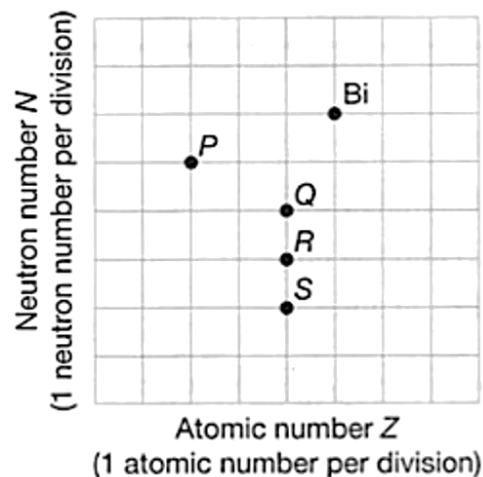

Bi decays to stable Pb by emitting an α -particle and a β -particle. Which of the points in the above figure represents the correct position of the stable Pb?

- A. *P*
 B. *Q*
 C. *R*
 D. *S*
33. The number of undecayed nuclides in two different samples *X* and *Y* are initially N and $8N$ respectively. If the ratio of the half-life of *X* to that of *Y* is 3:1, find the ratio of the number of undecayed nuclides of *X* to that of *Y* after three half-lives of *Y*.
- A. 1:4
 B. 1:2
 C. 2:1
 D. 4:1

34. In the following nuclear reaction 16.76 MeV of energy is released.

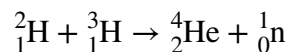

Which of the following statements about the nuclear reaction are correct?

(1 u = 1.661×10^{-27} kg, 1 u is equivalent to 931 MeV)

- (1) The reaction is a nuclear fusion.
 - (2) The neutron produced would cause the nuclear reaction to become a chain reaction.
 - (3) The total mass of ${}^2_1\text{H}$ and ${}^3_1\text{H}$ is bigger than that of ${}^4_2\text{He}$ and ${}^1_0\text{n}$ by 2.99×10^{-29} kg.
- A. (1) and (2) only
B. (1) and (3) only
C. (2) and (3) only
D. (1), (2) and (3)

End of Section A

Data

molar gas constant	$R = 8.31 \text{ J mol}^{-1} \text{ K}^{-1}$
Avogadro constant	$N_A = 6.02 \times 10^{23} \text{ mol}^{-1}$
acceleration due to gravity	$g = 9.81 \text{ m s}^{-2}$ (close to the Earth)
universal gravitational constant	$G = 6.67 \times 10^{-11} \text{ N m}^2 \text{ kg}^{-2}$
speed of light in vacuum	$c = 3.00 \times 10^8 \text{ m s}^{-1}$
charge of electron	$e = 1.60 \times 10^{-19} \text{ C}$
electron rest mass	$m_e = 9.11 \times 10^{-31} \text{ kg}$
permittivity of free space	$\epsilon_0 = 8.85 \times 10^{-12} \text{ C}^2 \text{ N}^{-1} \text{ m}^{-2}$
permeability of free space	$\mu_0 = 4\pi \times 10^{-7} \text{ H m}^{-1}$
atomic mass unit	$u = 1.661 \times 10^{-27} \text{ kg}$ (1 u is equivalent to 931 MeV)
astronomical unit	$\text{AU} = 1.50 \times 10^{11} \text{ m}$
light year	$\text{ly} = 9.46 \times 10^{15} \text{ m}$
parsec	$\text{pc} = 3.09 \times 10^{16} \text{ m} = 3.26 \text{ ly} = 206\,265 \text{ AU}$
Stefan constant	$\sigma = 5.67 \times 10^{-8} \text{ W m}^{-2} \text{ K}^{-4}$
Planck constant	$h = 6.63 \times 10^{-34} \text{ J s}$

Rectilinear motion

For uniformly accelerated motion:

$$v = u + at$$

$$s = ut + \frac{1}{2}at^2$$

$$v^2 = u^2 + 2as$$

MathematicsEquation of a straight line $y = mx + c$ Arc length $= r\theta$ Surface area of cylinder $= 2\pi rh + 2\pi r^2$ Volume of cylinder $= \pi r^2 h$ Surface area of sphere $= 4\pi r^2$ Volume of sphere $= \frac{4}{3}\pi r^3$ For small angles, $\sin \theta \approx \tan \theta \approx \theta$ (in radians)

Atomic World	Energy and Use of Energy
$\frac{1}{2}m_e v_{\text{max}}^2 = hf - \phi$ Einstein's photoelectric equation	$E = \frac{\Phi}{A}$ illuminance
$E_n = -\frac{13.6}{n^2} \text{ eV}$ energy level equation for hydrogen atom	$\frac{Q}{t} = \kappa \frac{A(T_H - T_C)}{d}$ rate of energy transfer by conduction
$\lambda = \frac{h}{p} = \frac{h}{mv}$ de Broglie formula	$U = \frac{\kappa}{d}$ thermal transmittance U-value
$\theta \approx \frac{1.22\lambda}{d}$ Rayleigh criterion (resolving power)	$P = \frac{1}{2}\rho Av^3$ maximum power by wind turbine

A1.	$E = mc\Delta T$	energy transfer during heating and cooling	D1.	$F = \frac{Q_1 Q_2}{4\pi\epsilon_0 r^2}$	Coulomb's law
A2.	$E = l\Delta m$	energy transfer during change of state	D2.	$E = \frac{Q}{4\pi\epsilon_0 r^2}$	electric field strength due to a point charge
A3.	$pV = nRT$	equation of state for an ideal gas	D3.	$E = \frac{V}{d}$	electric field between parallel plates (numerically)
A4.	$pV = \frac{1}{3} Nmc^2$	kinetic theory equation	D4.	$R = \frac{\rho l}{A}$	resistance and resistivity
A5.	$E_K = \frac{3RT}{2N_A}$	molecular kinetic energy	D5.	$R = R_1 + R_2$	resistors in series
			D6.	$\frac{1}{R} = \frac{1}{R_1} + \frac{1}{R_2}$	resistors in parallel
B1.	$F = m \frac{\Delta v}{\Delta t} = \frac{\Delta p}{\Delta t}$	force	D7.	$P = IV = I^2 R$	power in a circuit
B2.	moment = $F \times d$	moment of a force	D8.	$F = BQv \sin \theta$	force on a moving charge in a magnetic field
B3.	$E_P = mgh$	gravitational potential energy	D9.	$F = BIl \sin \theta$	force on a current-carrying conductor in a magnetic field
B4.	$E_K = \frac{1}{2} mv^2$	kinetic energy	D10.	$B = \frac{\mu_0 I}{2\pi r}$	magnetic field due to a long straight wire
B5.	$P = Fv$	mechanical power	D11.	$B = \frac{\mu_0 NI}{l}$	magnetic field inside a long solenoid
B6.	$a = \frac{v^2}{r} = \omega^2 r$	centripetal acceleration	D12.	$\mathcal{E} = N \frac{\Delta\Phi}{\Delta t}$	induced e.m.f.
B7.	$F = \frac{Gm_1 m_2}{r^2}$	Newton's law of gravitation	D13.	$\frac{V_s}{V_p} \approx \frac{N_s}{N_p}$	ratio of secondary voltage to primary voltage in a transformer
C1.	$\Delta y = \frac{\lambda D}{a}$	fringe width in double-slit interference	E1.	$N = N_0 e^{-kt}$	law of radioactive decay
C2.	$d \sin \theta = n\lambda$	diffraction grating equation	E2.	$t_{\frac{1}{2}} = \frac{\ln 2}{k}$	half-life and decay constant
C3.	$\frac{1}{u} + \frac{1}{v} = \frac{1}{f}$	equation for a single lens	E3.	$A = kN$	activity and the number of undecayed nuclei
			E4.	$\Delta E = \Delta mc^2$	mass-energy relationship